

3000 Series

Conventional Truck Stop Layout

NOT TO SCALE

The center islands can have more or less of the combination Master/Satellite dispensers. This layout allows the "Fuel Desk" to see each truck. It also allows the driver to step out of the truck at the Master dispenser where the fueling sale must be initiated. After starting the Master dispenser, the driver can walk around the truck to activate the Satellite dispenser.

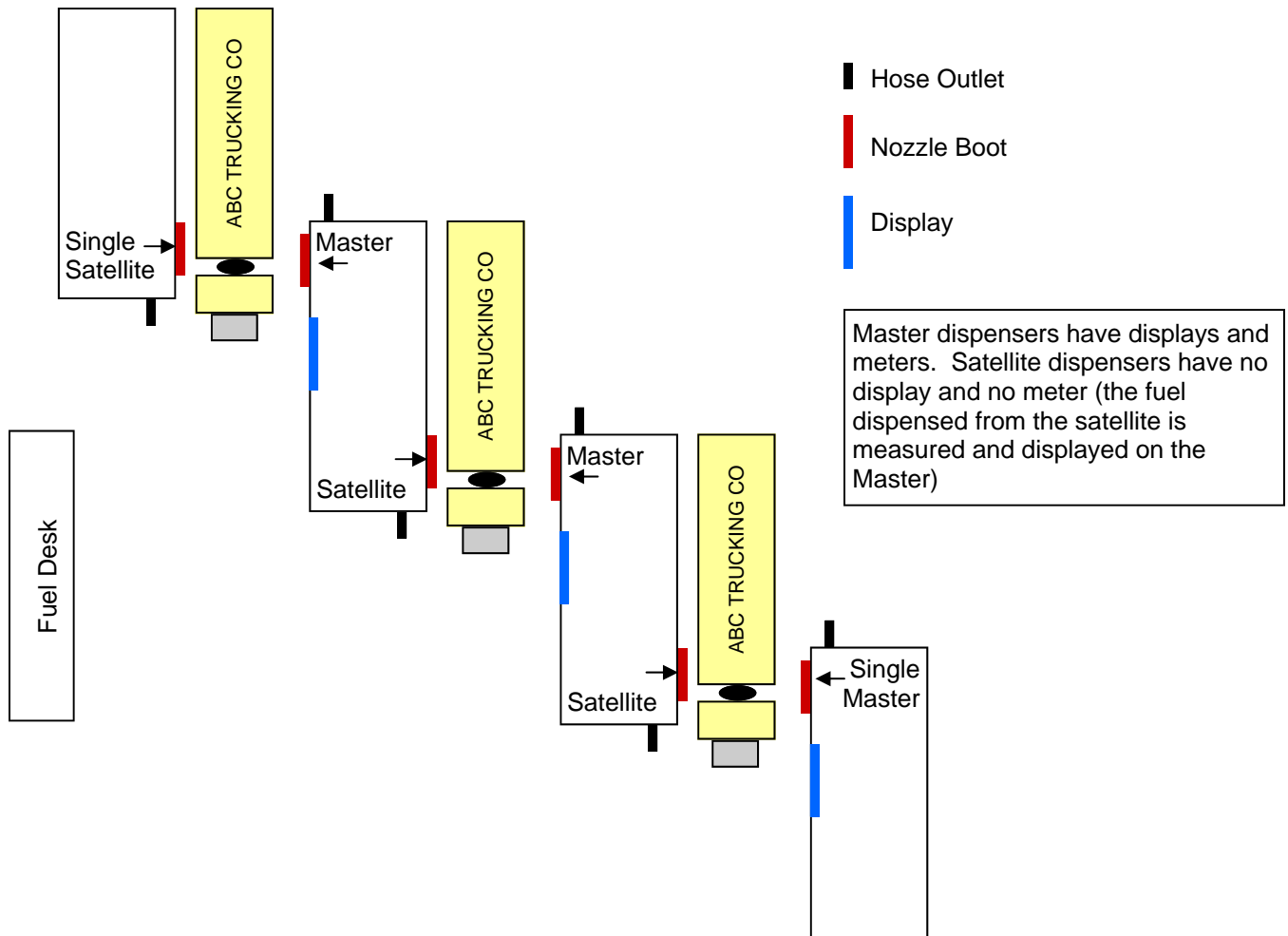

This page and the two pages following show the basic 3 most common layouts for Master/Satellite High Speed Truck Fueling. There are variations on each of these three themes. For help with any layouts, contact our Bid & Spec Desk at 800-235-7618, Ext. 3.

3000 Series

Unconventional Truck Stop Layout Using a Dual Master Dispenser in the Center

NOT TO SCALE

This layout often used where space is at a premium. Not the optimal for driver convenience....either one lane must exit their truck at the Satellite and walk around the truck to the master to initiate the fuel sale, or one lane must have traffic entering from the opposite direction.

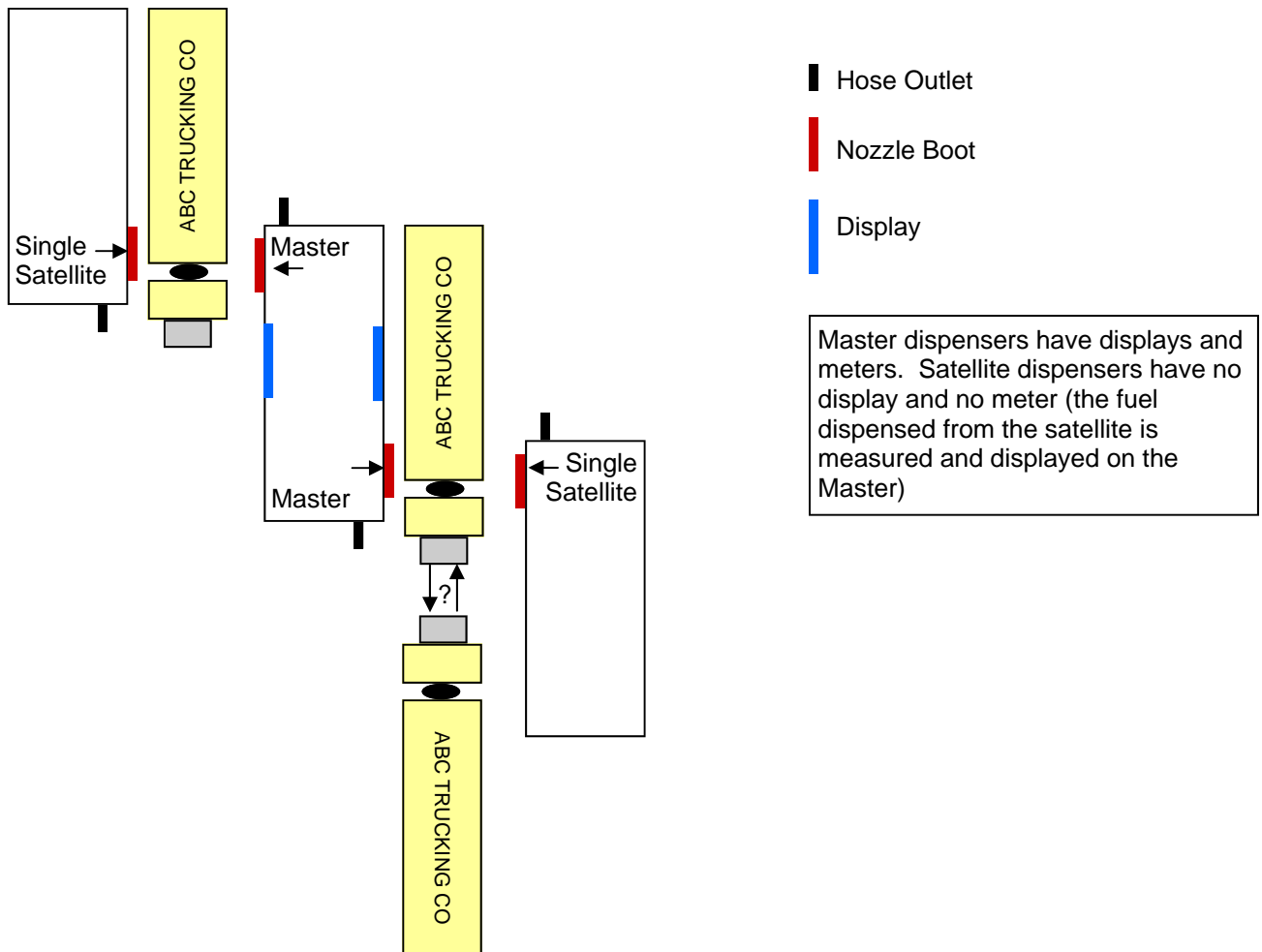

3000 Series

Unconventional Truck Stop Layout Using a Dual Satellite Dispenser in the Center

NOT TO SCALE

This layout often used where space is at a premium. Not the optimal for driver convenience...either one lane must exit their truck at the Satellite and walk around the truck to the master to initiate the fuel sale, or one lane must have traffic entering from the opposite direction.

